

MICOM RM500/RM500R 500W HF-SSB Rack-Mount Continuous Duty Transceivers Owner's Guide

Table of Contents

| | |
|--|----|
| Introduction..... | 1 |
| Description..... | 2 |
| General..... | 2 |
| Equipment Versions | 3 |
| Main Features | 3 |
| Major Accessories | 4 |
| Performance Specifications | 5 |
| Main Technical Characteristics | 5 |
| Accessories Connectors | 6 |
| Ordering Options..... | 7 |
| Familiarization with Equipment..... | 7 |
| RM500 Front Panel..... | 7 |
| RM500R Front Panel..... | 9 |
| RM500/RM500R Rear Panel | 9 |
| Equipment Installation | 11 |
| Installation Planning Guidelines..... | 11 |
| Preparations for Installation | 12 |
| Installation Procedure – Basic Radio..... | 13 |
| Installation Procedure – Radio with PPS Option | 13 |
| Operation..... | 16 |
| General..... | 16 |
| Preparations for Operation..... | 16 |
| Operating Instructions..... | 16 |
| Bypassing the 500W Amplifier Section | 16 |

Introduction

The MICOM RM500 (ordering option G160) and RM500R (ordering option G179) are 500W HF-SSB rack-mount continuous duty transceivers, part of the MICOM-3 line of HF-SSB radio sets.

This manual covers the installation and operation of the RM500/RM500R transceivers. The manual covers only procedures specific to the RM500 and RM500R; the other procedures, which are common to the whole MICOM-3 product line, are described in the "Owner's Guide, MICOM-3E/3T/3R HF-SSB Transceivers", Publication 6886867J01, and in the other applicable MICOM-3 Supplements that cover optional features.

Description

General

The MICOM RM500 and RM500R are 500W HF-SSB continuous duty radio sets. Figure 1 shows a general view of a typical 500W transceiver (the RM500R).

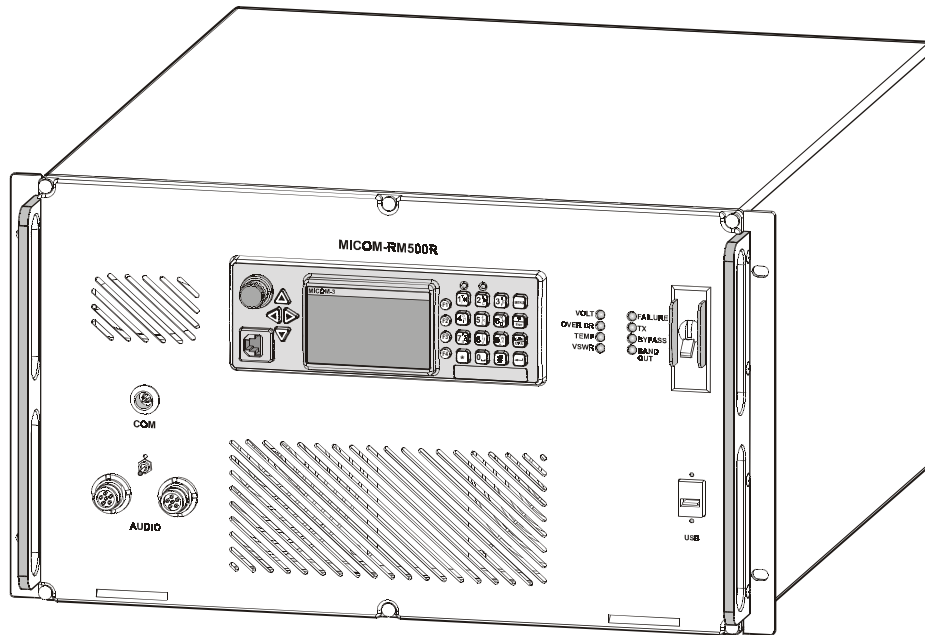

Figure 1. RM500R, General View

RM500 and RM500R expand the MICOM-3 product line by offering higher transmit power and thus longer reach, and improved communications under bad propagation conditions and/or strong interference.

An RM500 or RM500R radio set consists of a standard MICOM-3 transceiver tightly integrated with a 500W RF power amplifier and a 110/220 VAC, 50/60 Hz AC-powered power supply, all contained within a compact chassis suitable for installation in 19 in. racks and shelves. The AC input voltage range is automatically switched between 110 and 220 VAC, and therefore the equipment can be used in the United States of America as well as in other countries.

Internal cooling fans enable operation over a wide range of temperatures, for continuous-duty data transmission. The radio has multiple accessories connectors, for system interconnections.

For operation in multiple-transmitter or split sites, the RM500 and RM500R can be ordered with an interface for the Pre-Selector/Post-Selector (PPS) (option G65).

Note *The G65 option does not include the Pre-Selector/Post-Selector (PPS) unit, which must be separately ordered.*

The RM500/RM500R transceiver is very well suited for base station applications, and can be directly connected to a wide range of broadband or tuned antennas, including whip, dipole, traveling wave, delta, and semi-delta antennas.

To obtain maximum forward power, a low VSWR antenna system should be used; however, in case of excessive VSWR protection circuits prevent damage by reducing the transmit power to safe values.

Thus, the RM500 and RM500R will always attempt to transmit at the maximum safe power, even in case of mismatch.

Special circuits protect the RM500 and RM500R against overheating and various types of malfunctions. In case a critical problem is detected, the protection circuits are activated and bypass the internal 500W power amplifier: in this case, the MICOM-3 transceiver is directly connected to the antenna. This enables normal reception, as well as transmission, albeit at the lower power levels (up to 125W) the MICOM-3 transceiver can provide. Front panel indicators indicate the type of problem that has been detected, to help the operator correct it.

Being part of the MICOM-3 line, RM500 and RM500R offer similar capabilities and characteristics and use common operating procedures, thereby enabling personnel familiar with the operation of MICOM-3 equipment to start using the RM500/RM500R with minimal training.

Equipment Versions

MICOM RM500

Transceiver for long range wireless voice, fax, data and email communications.

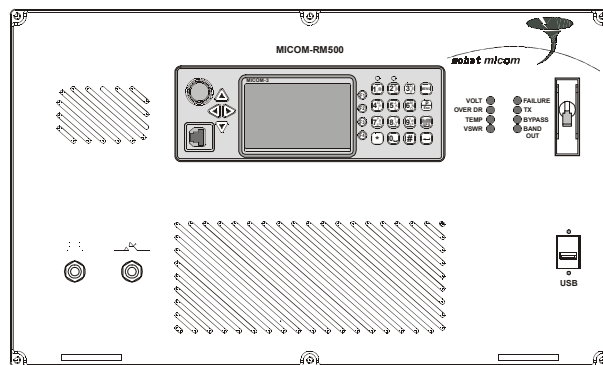

MICOM RM500R

Ruggedized transceiver with military handset and connectors, for applications requiring the utmost dependability and reliability.

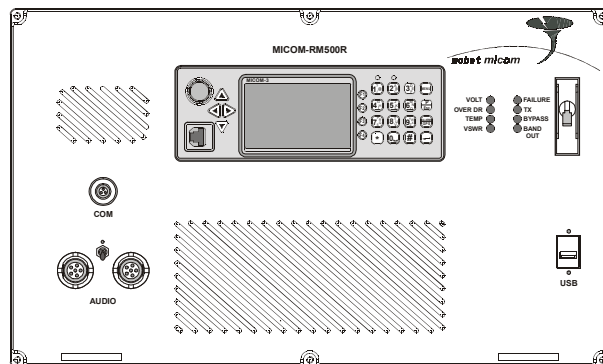

Main Features

- Automatic Link Establishment per FED-1045 & MIL-STD-188-141B (JITC certified)
- ISB (Independent Side Band) ready
- Full interoperability with other manufacturers' radios complying with the same ALE standards.

Voice that's loud & clear

- Built-in voice quality system utilizes proprietary algorithms to filter out background noises, giving users exceptional communication clarity.
- Selectable bandwidth allows fine tuning for optimal voice and data communications.
- Voice-activated digital squelch.

User-friendliness

- New control head features a large LCD, full-dot matrix digital display and an enhanced keyboard for programming and set-up.
- Radio operation can be executed using any standard USB keyboard.
- Multiple language display available.
- Transceiver can be controlled using PC and programming application.
- Remote control configuration, allows the transceiver to be operated from a remote location (at a distance of up to 5 km) using the optional 2-wire remote control head.

Years of trouble-free, most advanced communications

- Upgrading to future technologies is easily done by installing new software into the transceiver's DSP unit.
- Easily replaceable digital components ensure cost-effective maintenance.
- Very high MTBF, as with all MICOM radios.
- Unique Built-In self Test (BIT) system provides exceptional dependability.
- Protection circuits enable transmission at maximum safe power

Comprehensive communication and networking services

- Office-quality communication services integrating fax, e-mail and data transmission and reception.
- MultiNet option, enables integration of different HF radio networks into one seamless network, allowing excellent coordination between different operational nets.
- AMD (Automatic Message Display) for free and pre-set text messages.

A proven family of radio products

- RM500 and RM500R are members of the MICOM transceiver family – fixed and mobile stations – covering the long-range wireless communication needs of thousands of organizations worldwide.

Major Accessories

- Automatic telephone interconnect
- Antenna system
- Pre/Post-Selector (PPS)
- FM to HF repeater
- HF modems
- ATUs
- Antennas and grounding kit
- Secure voice and data
- Vocoder

Performance Specifications

Main Technical Characteristics

This section presents the main technical characteristics of the RM500 and RM500R. For a listing of the additional performance specs, refer to the “Owner’s Guide, MICOM-3E/3T/3R HF-SSB Transceivers”, Publication 6886867J01, and to the applicable MICOM-3 Supplements that cover the optional features available on your radio set.

| | | |
|-------------------|---|---|
| Models | <i>RM500</i> | M91AMN0KV5-K (option G160) |
| | <i>RM500R</i> | M95AMN0KV5-K (option G179) |
| General | <i>Number of channels</i> | 200 |
| | <i>Transmission frequency range</i> | 1.6 to 30 MHz |
| | <i>Transmit power (PEP and average)</i> | User-selectable levels: <ul style="list-style-type: none">• Max: 500 W• High: 400 W• Medium: 250 W• Low: 200 W |
| | <i>Reception frequency range</i> | 100 kHz to 30 MHz |
| | <i>Sensitivity (SINAD)</i> | 0.3 μ V for 10 dB SINAD |
| | <i>Audio bandwidth</i> | 350 to 2700 Hz |
| | <i>Data bandwidth</i> | 300 to 3300 Hz |
| | <i>Frequency stability</i> | 0.6 ppm (0.1 ppm optional) |
| | <i>Frequency resolution</i> | 10 Hz |
| | <i>Number of accessories connectors</i> | 4 (see Table 1) |
| | <i>Operating voltage</i> | 110 /220 VAC, 50/60 Hz, with automatic switching |
| | <i>Power requirements</i> | Max. 2000W |
| | <i>Operating temperature range</i> | -10°C to +60°C/14°F to +140°F |
| | <i>Humidity</i> | Up to 95%, relative humidity @ 50°C/122°F |
| Dimensions | <i>Height</i> | 290 mm/11.42 inch |
| | <i>Width</i> | 480 mm/18.9 inch |
| | <i>Depth</i> | 550 mm/21.7 inch |
| | <i>Weight</i> | 32 kg/70.6 lbs |

Accessories Connectors

The functions of the 25-pin accessories connectors, ACC-J1 to ACC-J4, are listed in Table 1. The connectors include PTT and CW control lines, audio and baseband lines for external equipment, auxiliary power output, serial RS-232 asynchronous data interfaces, and additional dedicated handshaking and control lines. The functions supported by the serial data interfaces are determined by the RM500/RM500R software.

Table 1. 25-Pin Accessories Connector, Pin Functions

| Pin | Designation | Description |
|-----|----------------|--|
| 1 | SPKR- | Differential output to the external 8 Ω , 8W speaker |
| 2 | EXT RX DATA- | Baseband output (0 dBm, 600 Ω) |
| 3 | SPKR+ | Differential output to the external 8 Ω , 8W speaker |
| 4 | EXT RX AUDIO+ | Differential received audio output (0 dBm, 600 Ω ; not controlled by volume, but affected by squelch) |
| 5 | EXT RX AUDIO- | |
| 6 | EXT TX AUDIO+ | Differential transmit audio input (600 Ω input impedance; 0 dBm is required for full power) |
| 7 | EXT TX AUDIO- | |
| 8 | PTT IN VOICE | Transmission command (short to ground) for voice signals |
| 9 | PTT IN DATA | Transmission command (short to ground) for data signals |
| 10 | PTT IN CW | Transmission command (short to ground) for CW (Morse) signals |
| 11 | SW A+ | Primary DC voltage current limited output (max 1A) |
| 12 | DSI/KW C C | BDM – Data serial in/external RF amplifier channel change |
| 13 | KW ON/OFF | External RF amplifier power on/off output |
| 14 | EXT RX DATA+ * | Baseband output (0 dBm, 600 Ω) |
| 15 | RXA | Receive input (point-to-point protocol to host/HLC) |
| 16 | TXA | Transmit output (point-to-point protocol to host/HLC) |
| 17 | EX RESET | External RESET input (for BDM) |
| 18 | GND | Ground |
| 19 | KW PTT | PTT output to external RF amplifier |
| 20 | EXT ALARM | External alarm output (open collector, pulled to ground when external alarm is activated) |
| 21 | VPP | Flash programming voltage, input to BDM |
| 22 | DSC/KW_ALC | BDM – Data serial clock/external RF amplifier ALC |
| 23 | SQ GATE | Squelch open/closed indication output |
| 24 | DSO/FAN ON/OFF | BDM – Data serial out/Fan control |
| 25 | FREEZE/KW TU | BDM – Freeze/external RF amplifier tune |

**RM500/RM500R
Main Options**

- USB port for external keyboard
- PC control and programming software package
- ALE DTM/DBM
- PPS interface
- Interface for VP-116 voice privacy device
- 2-wire remote control head

Ordering Options

| | | |
|----------------|----------|---|
| G424 (FVN4841) | Add | PC control and programming software package |
| S809 (FLN2515) | Enhanced | Interface cable kit for CW key & headphones |
| G112 | Enhanced | High frequency stability option (0.1 ppm) |
| G849 | Add | Interface option for external secure voice device (VP-116) |
| G419 | Enhanced | USB COM port for connecting external keyboard |
| G423 | Add | ALE DTM/DBM (data transfer message/data block message) |
| S308 (FLN2517) | Add | Interface cable kit for phone patch |
| G561 (FLN2530) | Add | Interface cable for MICOM link unit |
| G65 | Add | Interface for pre-post selector for co-site or split-site application |
| G420 | Add | 2-wire remote control head (up to 5 km) |

Familiarization with Equipment

RM500 Front Panel

The front panel of the RM500 includes a standard MICOM-3 control panel, and the additional items identified in Figure 2.

For a description of the MICOM-3 control panel, refer to the “Owner’s Guide, MICOM-3E/3T/3R HF-SSB Transceivers”, Publication 6886867J01; for indicator functions, refer to Table 2.

Table 2. RM500 Front Panel Indicators

| Indicator | Function |
|------------------|--|
| VOLT | Power supply fault indicator: lights when an internal supply voltage is out of limits. In this case, the 500W amplifier section cannot operate |
| OVER DR | Input overload indicator: lights when the RF drive power supplied to the 500W amplifier is too high. The 500W amplifier section is bypassed |

Table 2. RM500 Front Panel Indicators (Cont.)

| Indicator | Function |
|-----------|---|
| TEMP | <p>Amplifier overheat indicator: lights when the internal temperature is too high. Usually, this occurs when the air intake or exhaust vents are accidentally obstructed, prolonged exposure to direct sun radiation, or excessive ambient temperatures.</p> <ul style="list-style-type: none"> • If the FAILURE indicator flashes while TEMP lights but BYPASS is off, the 500W amplifier continues transmitting at half power • If the FAILURE and BYPASS indicators light together with TEMP, the 500W amplifier has switched to the bypass mode |
| VSWR | <p>Excessive VSWR indicator: lights when the 500W amplifier is in the transmit mode to indicate that the antenna VSWR exceeds the maximum allowed. This may be caused by a disconnected feed cable, an improperly installed or incorrectly tuned antenna, or as a result of damage to the antenna or to its feed cable</p> |
| FAILURE | <p>PA failure indicator:</p> <ul style="list-style-type: none"> • Lights when a critical fault in the 500W amplifier section prevents its operation. In this case, BYPASS also lights, to indicate that the 500W amplifier is bypassed • Flashes when an operational problem, for example, high temperature, excessive drive power or excessive VSWR activates the corresponding protection circuits |
| TX | <p>Transmission mode indicator: lights when the 500W amplifier operates in the transmit mode</p> |
| BYPASS | <p>Bypass mode indicator: lights when the 500W amplifier is bypassed. The amplifier is normally bypassed when the radio is in the receive mode. It is also bypassed when a fault or abnormal condition prevents its normal operation</p> |
| BAND OUT | <p>Out-of-band input signal frequency: lights when the output filter of the 500W amplifier (used to reduce harmonics radiated by the radio set), cannot be tuned to the input signal frequency. In this case, the highest filter band is selected to attempt continued operation</p> |

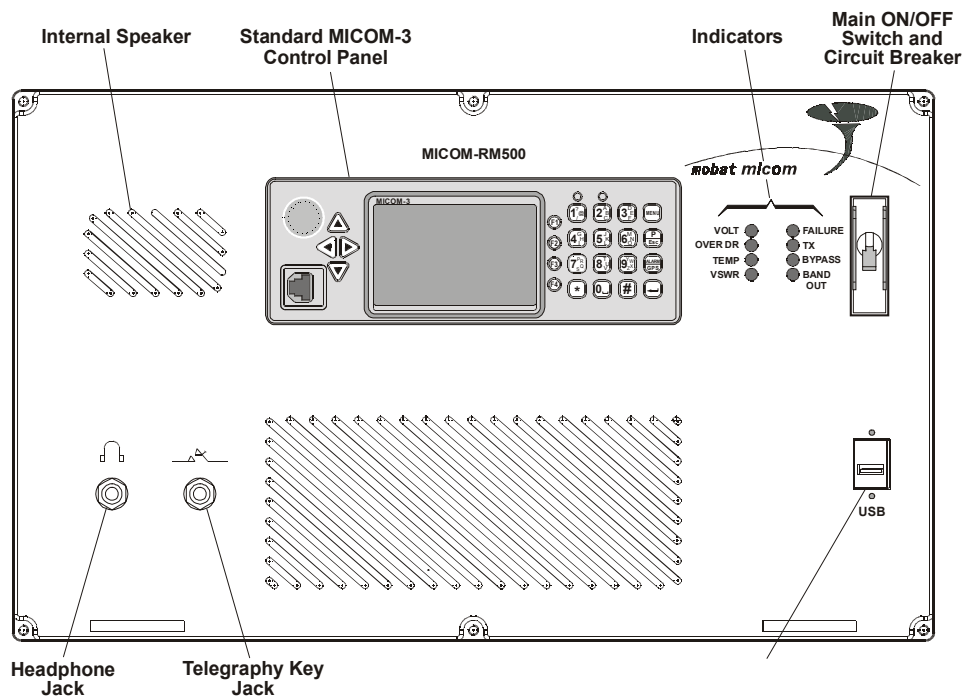

Figure 2. RM500 Front Panel

RM500R Front Panel

The front panel of the RM500R is shown in Figure 3. Refer to Table 2 for indicator functions.

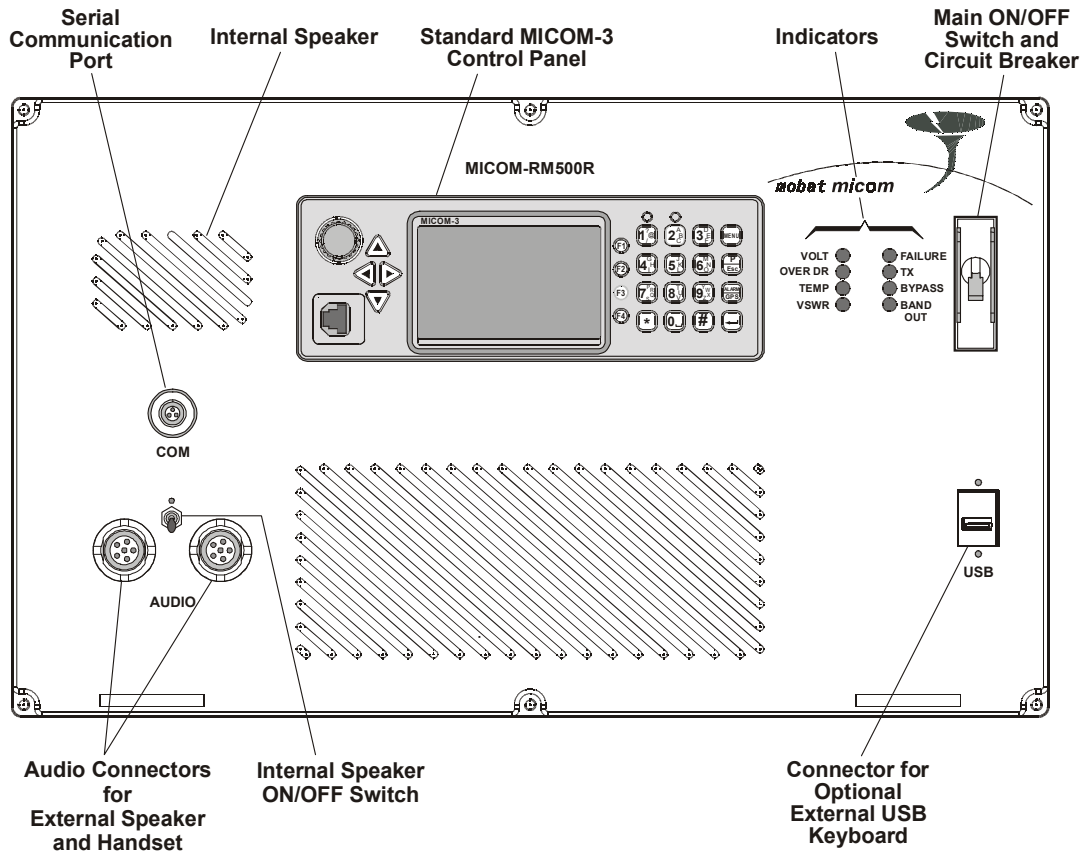

Figure 3. RM500R Front Panel

RM500/RM500R Rear Panel

Figure 4 shows the rear panel of the RM500 and RM500R. The functions of the various items are explained in Table 3.

Table 3. RM500/RM500R Rear Panel Items

| Item | Description | Function |
|------|--------------------------|--|
| 1 | AC Power Cable | Connection to AC power source |
| 2 | RF OUT Connector | UHF connector for connection of feed cable to antenna. Serves as the radio set RF input in the receive mode, and as the RF output in the transmit mode |
| 3 | REMOTE CONTROL Switch | Enables/disables remote control by the optional 2-wire control head |
| 4 | REMOTE CONTROL Terminals | Connection of 2-wire line to optional 2-wire control head |
| 5 | Grounding Screw | Connection of ground to the 500W power amplifier section |
| 6 | RX OUT Connector | BNC RF output connector, for connection of unfiltered RF receive signal to the optional pre/post-selector (PPS) |

Table 3. RM500/RM500R Rear Panel Items (Cont.)

| Item | Description | Function |
|------|-----------------------------|---|
| 7 | TX OUT Connector | BNC RF output connector, for connection of unfiltered RF transmit signal to the optional pre/post-selector (PPS) |
| 8 | TUNER CONTROL Connector | Connection of control signals to the optional pre/post-selector (PPS) |
| 9 | ACC-J1 to ACC-J4 Connectors | Four 25-pin D-type male connectors, for connection to external accessories, for example, voice privacy devices, modems, vocoders, etc. Connector ACC-J2 is used for connection to the parallel I/O interface of the optional pre/post-selector (PPS) |
| 10 | Grounding Screw | Connection of ground to the transceiver section |
| 11 | TX IN Connector | BNC RF input connector, for connection of filtered RF transmit signal from the optional pre/post-selector (PPS) |
| 12 | RX IN Connector | BNC RF input connector, for connection of filtered RF receive signal from the optional pre/post-selector (PPS) |

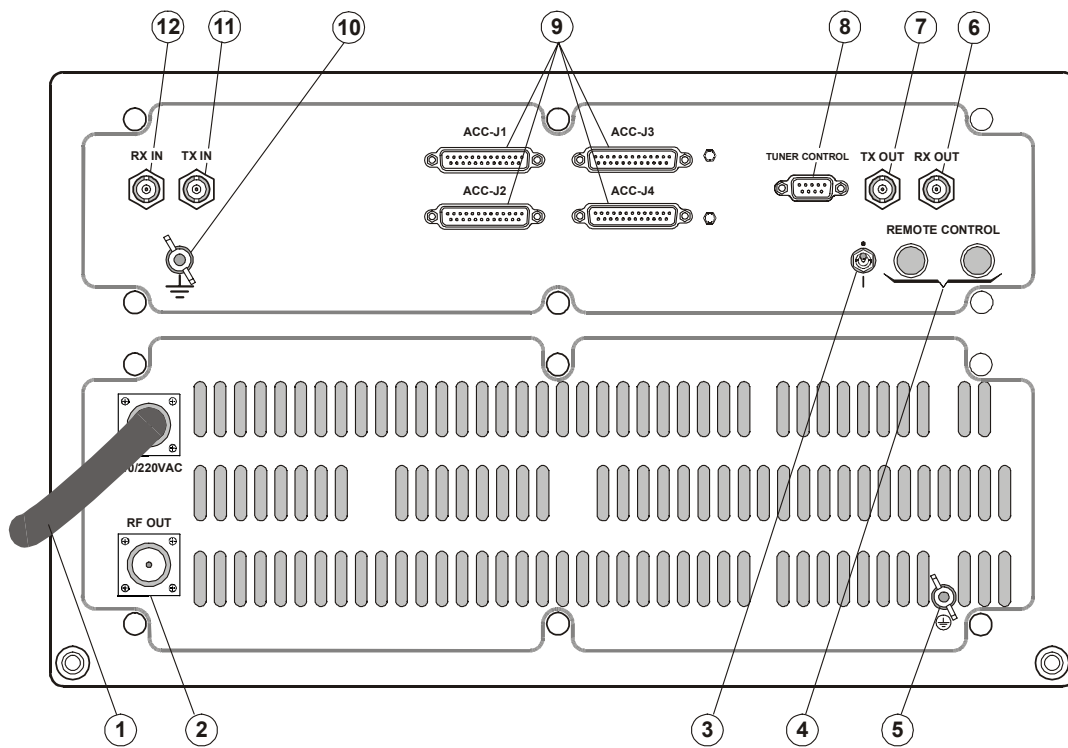

Figure 4. RM500/RM500R Rear Panel

Equipment Installation



Warning

For general operating and installation safety information, see the “Owner’s Guide, MICOM-3E/3T/3R HF-SSB Transceivers”, Publication 6886867J01.

During installation work, strictly observe the applicable safety precautions and local regulations. Do not work on the antenna system during lightning storms.



Warning

Proper grounding is essential for your safety, and for good communication performance.

Do not touch the antenna and the RF connectors while the RM500/RM500R operates. During transmission, high RF voltages appear at the RF connectors, the antenna cables, and on the antenna itself. These voltages may cause severe injury or death on contact.

Make sure the antenna is not located near high-voltage lines.

All personnel must be familiar with the applicable safety requirements before attempting to install or operate the RM500/RM500R. Severe injury or death could result from failure to comply with the safety practices.



Caution

The RM500/RM500R is a two-person lift. Make sure that help is available during the installation activities.

Installation Planning Guidelines

This section provides information necessary for planning the installation of RM500/RM500R.

Grounding

Failure to provide proper grounding will degrade system operation and cause RF voltage to be present on the equipment chassis. A possible serious hazard to personnel could result, as well as equipment malfunction.

Wide copper straps, as short as possible, must be used for grounding. These straps must be clamped or bonded to a reliable, low-resistance grounding system.

Power Requirements

The RM500/RM500R requires AC power at a nominal voltage of 110 or 220 VAC, 50/60 Hz. The RM500/RM500R will automatically select the appropriate voltage range. The AC power consumption during high-power transmission is up to 2 kW.

A suitably rated circuit breaker must be used to protect the supply line to the RM500/RM500R. It must also enable disconnection of supply voltage during installation and maintenance.

Cooling

RM500/RM500R units are cooled by internal fans. Air is taken in through the front panel vent, and discharged toward the rear. Therefore, make sure that sufficient free space is available around the equipment to enable free air flow.

Do not stack equipment units: leave at least 1U free above and below the RM500/RM500R.

Installation Data

The RM500/RM500R are intended for installation in 19 in. racks. The equipment has front-mounted brackets for attachment. To provide convenient access during maintenance, the RM500/RM500R may be installed in a sliding drawer or on slides capable of supporting the equipment weight.

Make sure that sufficient rack space is available for installation of other options, for example, the 1U-high PreSelector/PostSelector (PPS).

The rack must be connected to a reliable, low-resistance grounding system.

Sufficient front and rear clearance is required to permit convenient access to front and rear panels, as well as for removal and installation of equipment units, connection of cables, and maintenance.

Antenna System

Antenna systems are selected in accordance with the specific communication requirements of each customer: many HF antenna types are available, each providing different radiation characteristics to meet different communication requirements. Therefore, the selection and installation of an antenna system is customer's responsibility. If necessary, contact Mobat or your local Mobat representative for additional information.

The antenna system must provide a matched termination at the operating frequency, and must be capable of handling the maximum power output of the RM500/RM500R.

Antenna Feed System

The antenna feed system comprises any cables, panels and matrices, and any accessories that carry HF signals between the RM500/RM500R and the antenna itself.

All the antenna feed system components, and in particular the feed cable, must have low loss and be capable of carrying the maximum power output of the RM500/RM500R. Remember that any power loss along the cable is signal loss!

To protect yourself and the radio equipment against lightning strokes and accidental contact of antenna and/or feed cable with high voltage lines, a properly grounded coaxial protector must be installed at the point of entry of the feed cable into the building or communication shelter. The recommended protector type is IS-B50LN-C0 by PolyPhaser Corp. (also available from Mobat, as Cat. No. 2072-09128-00).

Preparations for Installation

Before starting the installation of a new RM500/RM500R, review the installation plan and make the following checks:

1. Identify the prescribed location of the equipment in the rack or cabinet, and check the mounting surface, and the mounting holes. Thoroughly clean the mounting surface and remove all paint, grease and dirt from the holes to provide a better grounding connection.

2. Check availability of AC power, and grounding arrangements.
3. Check antenna installation, in accordance with the antenna installation and operation manual.
4. Check the cable runs between the RM500/RM500R and the prescribed antenna, including the coaxial protector. Make sure that the cables are securely fastened, and do not show signs of external damage.

Note Before installing the RM500/RM500R on slides, make sure you are familiar with the procedures needed to install slides in the rack/cabinet, and to safely install heavy equipment on the slides.

Installation Procedure – Basic Radio

1. Identify the installation position of the RM500/RM500R in the rack.
2. Install the RM500/RM500R in the prescribed installation position, fastening it by means of four screws to the rack rails or to the drawer front.
3. Connect grounding straps from each of the two RM500/RM500R grounding screws (located on its rear panel), to the prescribed cabinet's grounding bar.
4. Set the power switch on the RM500/RM500R front panel to OFF (down position).
5. Connect cables to the unit as follows:
 - Connect the RM500/RM500R AC power cable to the prescribed outlet on the power distribution box of the cabinet.
 - Connect the antenna feed cable to the RF OUT connector of the RM500/RM500R.
 - When an external device is used, connect the prescribed cable to the accessories connector of the RM500/RM500R that supports the corresponding device.
6. Connect audio accessories to the front panel connectors.

Installation Procedure – Radio with PPS Option

PPS Functions

The optional Preselector/Postselector, PPS-100 (referred to as **PPS** in this manual), supported as an option by the RM500/RM500R, permits operation of collocated receivers and transmitters on frequencies separated by as little as 10%. The PPS operating frequency range is 1.60 to 29.99 MHz.

To use the PPS, order the RM500/RM500R with option G65. The connections between an RM500/RM500R with option G65 and the PPS are shown in Figure 5.

When the G65 option is installed, the PPS is controlled by the RM500/RM500R through serial and parallel ports and is automatically inserted by the RM500/RM500R in the signal path in accordance with the operating mode:

- In the receive mode, the PPS functions as a preselector, providing an additional front end selectivity stage for the receive path of the RM500/RM500R. This reduces the receiver desensitization and overload that would normally occur in the presence of strong adjacent RF transmissions.

- In the transmit mode, the PPS is used as a postselector. It attenuates spurious signals and broadband noise in the driver transmit signal before it reaches the internal 500W power amplifier, thereby reducing interference to neighbouring receivers.

In both modes, the PPS automatically tracks the RM500/RM500R operating frequency. Rapid tuning makes the PPS suitable for Automatic Link Establishment (ALE) or Adaptive Applications.

During self-test, the PPS automatically switches to the bypass mode: in this mode, RF signals pass directly through the PPS, without filtering, and therefore does not interfere with system operation. The PPS also switches to the bypass mode when the RM500/RM500R frequency is outside the PPS operating range, 1.60 to 29.99 MHz.

In case excessive RF power is applied to the PPS, the PPS enters the RF overload protection mode: in this mode, the PPS antenna port is disconnected, and the internal antenna input is short-circuited to ground. This also protects the RM500/RM500R internal transceiver against overload.

The PPS is housed in a 1U high (1.75 in.) case intended for 19 in. rack mounting. Standard operation is from 115 or 230 VAC, 50/60 Hz, and can also be powered from 12 or 24 VDC DC sources.

PPS Installation Procedure

Note *The following procedure assumes that the basic RM500/RM500R unit has already been installed, as explained above (page 13).*

1. Identify the installation position of the PPS in the rack, and the position of the RM500/RM500R to which it will be connected.
2. Install the PPS in the prescribed installation position, fastening it by means of four screws to the rack rails or to the drawer front.
3. Connect a grounding strap from the RM500/RM500R grounding screw to the prescribed cabinet's grounding bar.
4. Set the power switches on the RM500/RM500R and PPS front panels to OFF (down position).
5. Connect the PPS AC power cable to the prescribed outlet on the power distribution box of the cabinet.
6. Refer to Figure 5 and connect cables between RM500/RM500R and the PPS as follows:

| RM500/RM500R Connector | PPS Connector |
|-------------------------------|----------------------|
| TUNER CONTROL | SERIAL I/O |
| ACC-J2 | PARALLEL I/O |
| RX IN | ANTENNA |
| TX IN | EXEC OUT |
| TX OUT | PA IN |
| RX OUT | RADIO |

This completes the installation of the PPS.

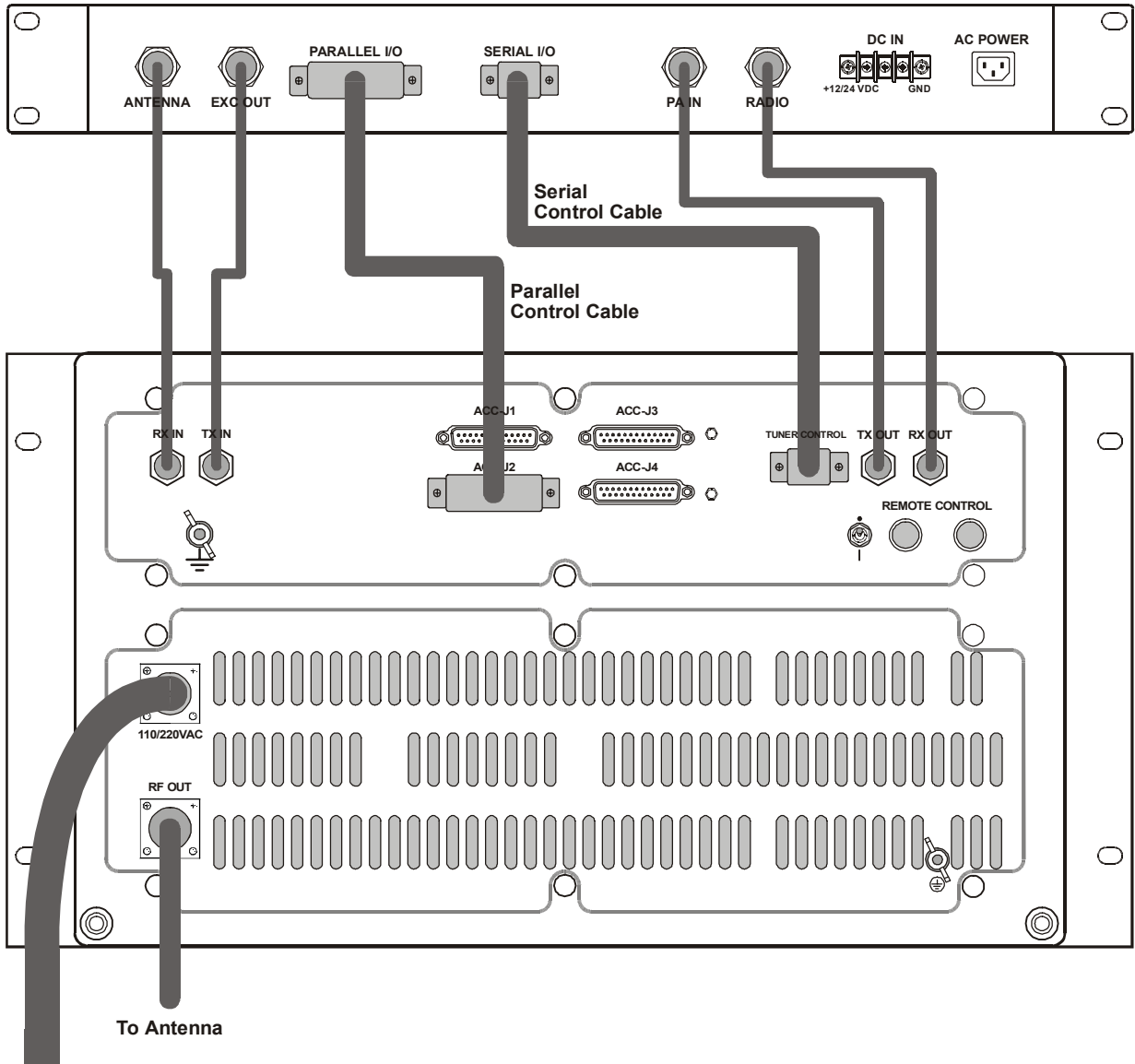

Figure 5. Connections to Optional PPS

Operation

General

The following instructions present operating procedures specific to the RM500 and RM500R. It is assumed that the operator is familiar with the common MICOM-3 operating procedures; if necessary, refer to the “Owner’s Guide, MICOM-3E/3T/3R HF-SSB Transceivers”, Publication 6886867J01, and to the applicable MICOM-3 Supplements that cover optional features.

Preparations for Operation

1. Set the REMOTE CONTROL switch on the rear panel of the RM500/RM500R to the OFF (down) position.
2. For the RM500R, set the internal speaker switch to ON (up).

Operating Instructions

1. Turn the radio on by setting its main switch to ON (up).
2. Adjust the volume control to a comfortable listening level.
3. You are now ready to start using the RM500/RM500R. For operating procedures, you may use the information appearing in the “Owner’s Guide, MICOM-3E/3T/3R HF-SSB Transceivers”, Publication 6886867J01.
4. To turn the radio off, set its main switch to OFF (down).

Bypassing the 500W Amplifier Section

The internal 500W amplifier section of the RM500/RM500R can be permanently bypassed. In this case, you can still transmit at a power of up to 125W using the capabilities of the MICOM-3 transceiver which is part of the RM500/RM500R.

You can bypass the 500W amplifier section in case the full transmit power of the RM500/RM500R is not needed (for example, good communication conditions), to save power (the maximum power consumption then decreases to approx. 500W), or when a technical problem in the 500W amplifier section prevents its operation.

To bypass the 500W amplifier section, select **NONE** on the **PROG>RAD>OPTS>ACC** menu.